

HPS CONNECTOR

Board-to-wire/Sealed connector

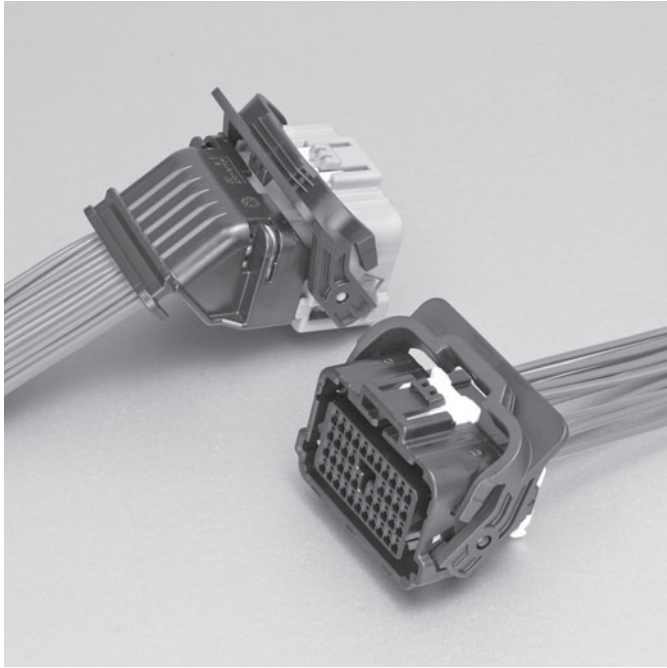

40 Circuits 0.64 Sealed Connector

■ Features

- Water / Dust protection
- Connector Position Assurance (CPA) Mechanism
- Key Option is available.
- Independent Secondary Lock Design
- Mechanical Assist Lever (Vertical motion)
- High Temperature Resistance
- Wire Dressing Cover is optional

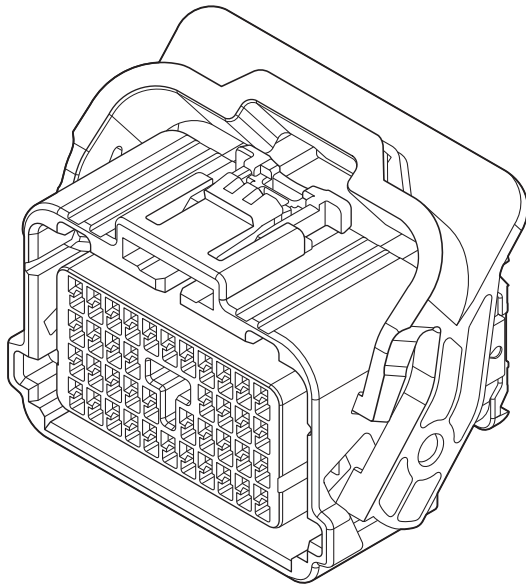

■ Specifications

- Current rating: 5A AC, DC max.
- Voltage rating: 14V AC, DC
- Temperature range: -40°C to +125°C
(including temperature rise in applying electrical current)
- Contact resistance: Initial value/15mΩ max.
After environmental testing/15mΩ max.
- Insulation resistance: 100MΩ min.
- Withstanding voltage: 1,000V AC/minute
- Applicable wire: SAE/ AVSS/ CAVS/ FLR2X-B
0.3mm² to 0.85mm²

* Compliant with ELV/RoHS.
* Contact JST for details.

Female terminal

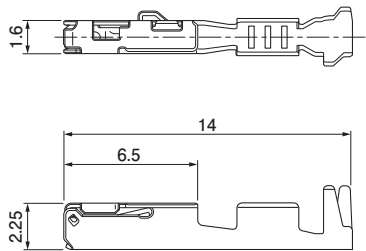

Model No.	Applicable wire range		Q'ty/reel
	Conductor (mm ²)	Insulation O.D. (mm)	
①SAIT-A03T-M064	0.3 to 0.5	≤1.9	6,500
①SAIT-A02T-M064	0.75 to 0.85	≤1.9	6,500
②SAIT-A03GF-M064	0.3 to 0.5	≤1.9	6,500
②SAIT-A02GF-M064	0.75 to 0.85	≤1.9	6,500

Material and Finish

- ①Copper alloy, tin-plated (reflow treatment)
- ②Copper alloy, nickel-undercoated, Contact area; gold-plated
Barrel area; tin-plated

Female connector

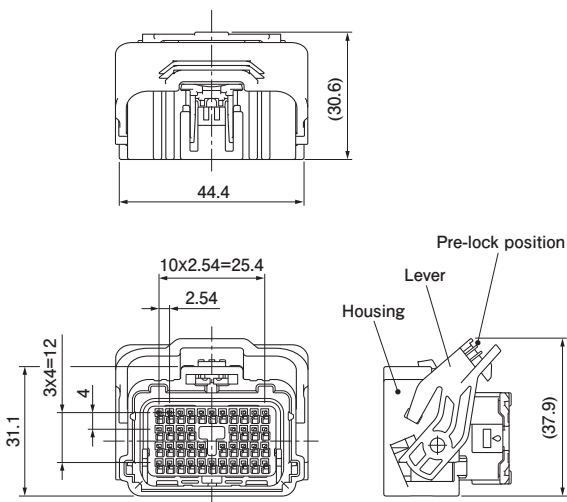

Circuits	Model No.	Q'ty/box	Color	
			Housing	Wire Seal Cover
9	HPSPB-C40C09-AK	336	Black	Black
12	HPSPB-C40C12-AK	336	Black	Natural
21	HPSPB-C40C21-BH	336	Gray	Black
31	HPSPB-C40C31-BH	336	Gray	Gray

Material

- Housing: PBT
- Retainer: Glass-filled PBT, natural
- CPA: Glass-filled PBT, natural
- Ring seal: Silicone, green
- Harness seal: Silicone, green
- Lever: Glass-filled PBT, black
- Wire seal cover: Glass-filled PBT

Wire dressing cover

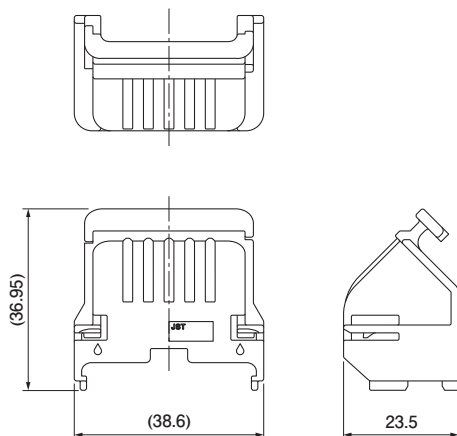

Model No.	Q'ty/box
HPSWC-40-K	100

Material

Glass-filled PBT, black

HPS CONNECTOR

Assembly layout (with Wire dressing cover)

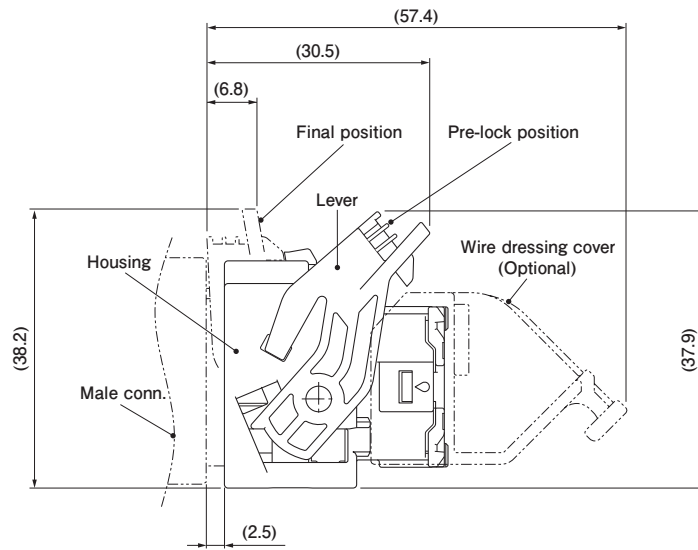

Crimping machine, Applicator

Strip terminal	Crimping machine	Crimp applicator MKS-L	
		Dies	Crimp applicator with dies
SAIT-A03()-M064	AP-K2N	MK/SAIT-A03-064	APLMK SAIT-A03-064
SAIT-A02()-M064		MK/SAIT-A02-064	APLMK SAIT-A02-064

Note: When crimping operation is conducted using an applicator and die set other than the above, JST cannot guarantee the performance of the terminal.