

# SACCONNECTOR

Wire-to-wire/Sealed connector



Miniaturized 0.64 mm Sealed wire-to-wire connector for automotive application.

## ■ Features

- Ultra Miniaturized 0.64 Sealed Female Connector for extremely tight packaging conditions

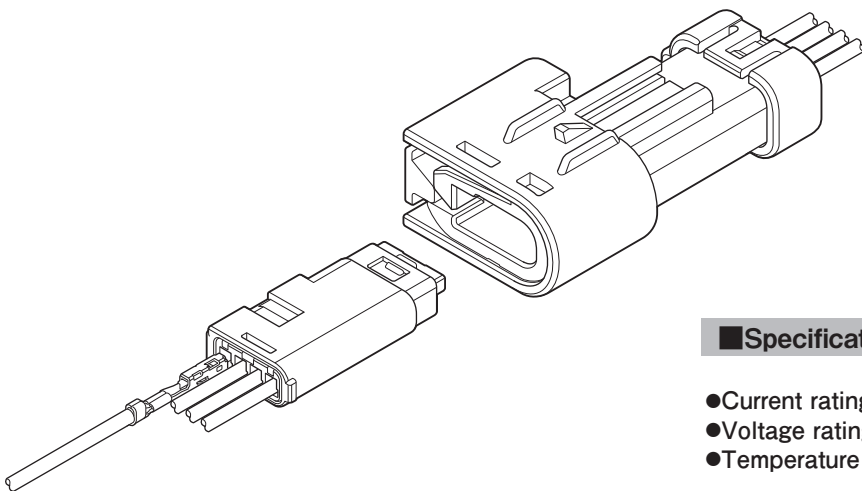

## ■ Specifications

- Current rating: 5 A DC max.
- Voltage rating: 14 V DC
- Temperature range: -40°C to +125°C  
(including temperature rise in applying electrical current)
- Contact resistance: Initial value/ 15 mΩ max.  
After environmental tests/ 15 mΩ max.
- Insulation resistance: 100 MΩ min.
- Applicable wire: SAE/ AVSS/ CAVS  
0.3 mm<sup>2</sup> to 0.8 mm<sup>2</sup>

\* Compliant with ELV/RoHS.  
\* Contact JST for details.

## Female terminal

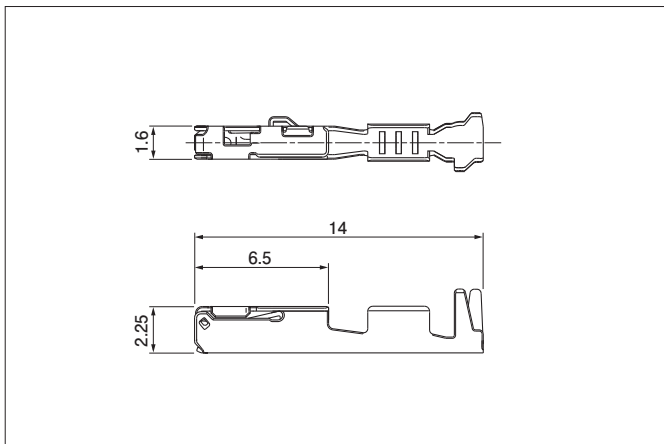

Model No.	Applicable wire range		Q'ty/reel
	Conductor (mm <sup>2</sup> )	Insulation O.D. (mm)	
①SAIT-A03T-M064	0.3 to 0.5	≤1.9	6,500
①SAIT-A02T-M064	0.75 to 0.8	≤1.9	6,500
②SAIT-A03GF-M064	0.3 to 0.5	≤1.9	6,500
②SAIT-A02GF-M064	0.75 to 0.8	≤1.9	6,500

### Material and Finish

- ①Copper alloy, tin-plated (reflow treatment)
- ②Copper alloy, nickel-undercoated, Contact area; gold-plated  
Barrel area; tin-plated

## Female connector

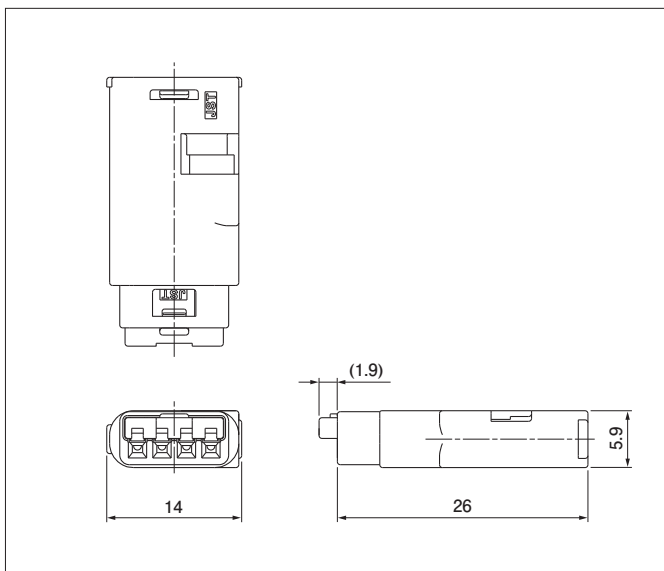

Circuits	Model No.	Q'ty/box
4	SACWPB-04-K	400

### Material and Finish

- Housing: Glass-filled PBT, Black
- TPA: Glass-filled PBT, Red
- Cover: Glass-filled PBT, Black
- Connector seal: Silicone, Green

## Male terminal

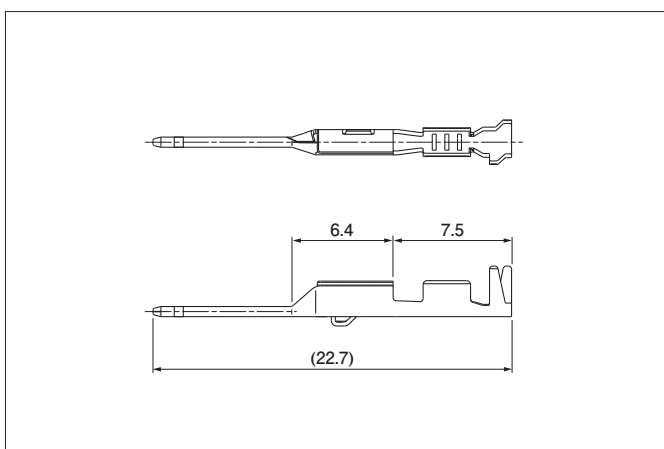

Model No.	Applicable wire range		Q'ty/reel
	Conductor (mm <sup>2</sup> )	Insulation O.D. (mm)	
①SAITW-A03T-064	0.3 to 0.5	≤1.9	9,000
①SAITW-A02T-064	0.75 to 0.8	≤1.9	7,000
②SAITW-A03GF-064	0.3 to 0.5	≤1.9	9,000

### Material and Finish

- ①Brass, tin-plated (reflow treatment)
- ②Brass, nickel-undercoated, Contact area; gold-plated  
Barrel area; tin-plated

# SAC CONNECTOR

## Male connector

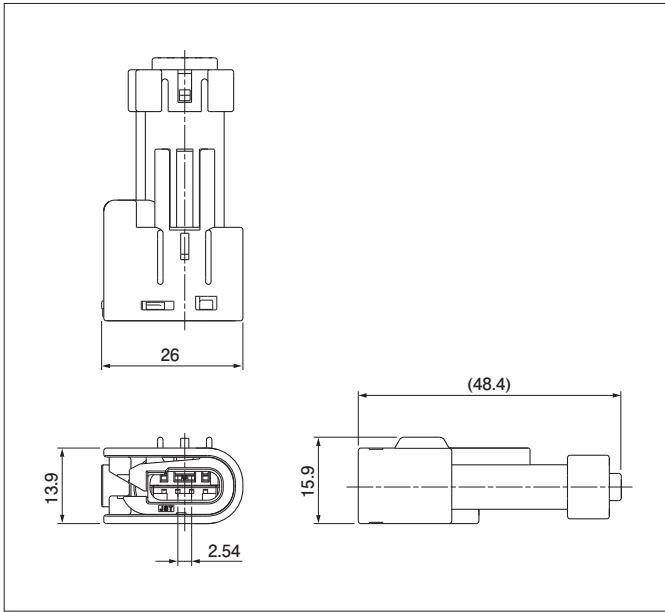

Circuits	Model No.	Q'ty/box
4	SACWSB-04-K	1,200

### Material and Finish

Housing: Glass-filled PBT, Black  
 Retainer: Glass-filled PBT, Red  
 Back cover: Glass-filled PBT, Black  
 Ring seal & Wire seal: Silicone, Green  
 Retention clip: Glass-filled PBT, Natural (White)

## Assembly layout

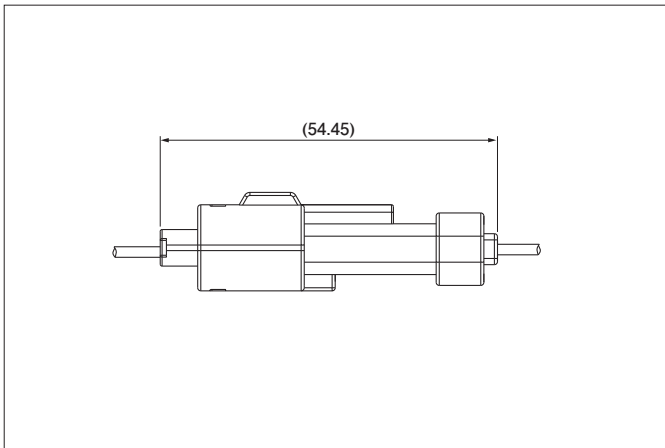

## Crimping machine, Applicator

Strip terminal	Crimping machine	Crimp applicator MKS-L	
		Dies	Crimp applicator with dies
SAIT-A03( )-M064	AP-K2N	MK/SAIT-A03-064	APLMK SAIT-A03-064
SAIT-A02( )-M064		MK/SAIT-A02-064	APLMK SAIT-A02-064
SAITW-A03( )-M064		MK/SAITW-A03-064	APLMK SAITW-A03-064
SAITW-A02( )-M064		MK/SAITW-A02-064	APLMK SAITW-A02-064

Note: When crimping operation is conducted using an applicator and die set other than the above, JST cannot guarantee the performance of the terminal.