

# HM CONNECTOR

2.5 mm pitch/Wire-to-wire connectors - Matable with HR receptacles

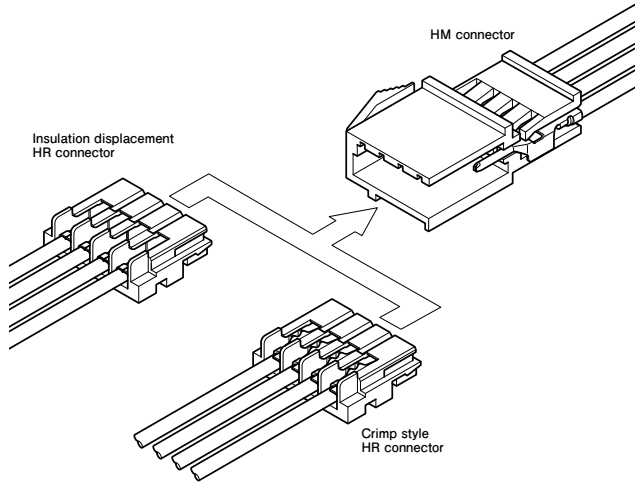

- Both crimp style and insulation displacement receptacles can be used
- Housing-to-terminal locks
- Mountable on a variety of panels
- Highly reliable housing construction

## Specifications

- Current rating: Crimp style HR connectors type  
3 A AC/DC  
Insulation displacement HR connectors type  
2 A AC/DC
- Voltage rating: 250 V AC/DC (See Note below.)
- Temperature range: -25°C to +85°C  
(including temperature rise in applying electrical current)
- Contact resistance: Initial value/ 10 mΩ max.  
After environmental tests/ 20 mΩ max.
- Insulation resistance: 500 MΩ min.
- Withstanding voltage: 1,000 VAC/minute
- Applicable wire: AWG #26 to #22  
0.13 to 0.33 mm<sup>2</sup>
- Applicable panel thickness: 0.8 to 1.6 mm

Note: Contacts are exposed at the housing lances.

Care should be taken so that these parts do not touch the metal section of the chassis.

\* In using the products, refer to "Handling Precautions for Terminals and Connectors" described on our website (Technical documents of Product information page).

\* RoHS2 compliance

\* Dimensional unit: mm

\* Contact JST for details.

\* RoHS2 compliance

## Standards

Recognized E60389

## Panel layout and Assembly layout

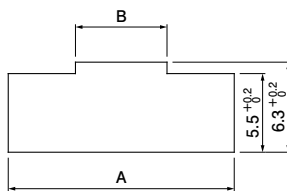
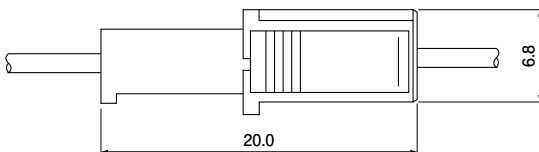

No. of circuits	Housing	Panel hole dimensions (mm) General tolerance		Applicable panel thickness (mm)
		A $\begin{smallmatrix} +0.2 \\ 0 \end{smallmatrix}$	B $\begin{smallmatrix} +0.2 \\ 0 \end{smallmatrix}$	
2	HMR-02V	13.3	3.9	0.8~1.6
3	HMR-03V	15.8	6.4	
4	HMR-04V	18.3	8.9	
8	HMR-08V	28.3	18.9	
12	HMR-12V	38.3	28.9	

- Note: 1. Punch holes in the panel according to the sketch and table shown above. Burrs must be removed.  
2. The strength of the panel must be considered when punching two or more holes.  
3. The connector must be inserted from the same side as the hole is punched.

## Plug / HM connector

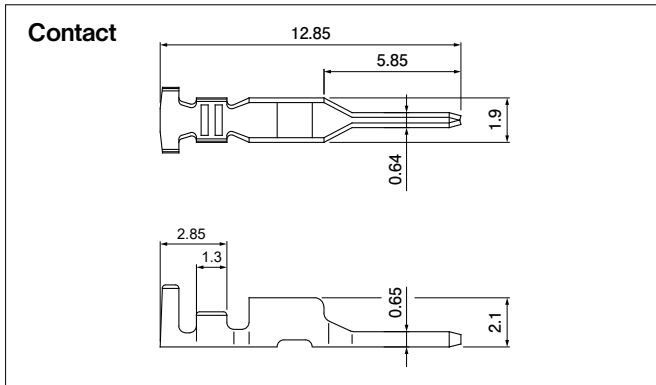

Model No.	Applicable wire		Insulation O.D. (mm)	Q'ty/reel
	mm <sup>2</sup>	AWG #		
SMR-001T-0.6	0.13~0.33	26~22	1.3~1.7	9,000

### Material and Finish

Brass, tin-plated (reflow treatment)

RoHS2 compliance

Contact	Crimping machine	Applicator		
		Crimp applicator	Dies	Crimp applicator with dies
SMR-001T-0.6	AP-K2N	MKS-L	MK/SHR/MR-001-06	APLMK SHR/MR001-06

Note: Contact JST for fully automatic crimping applicator.

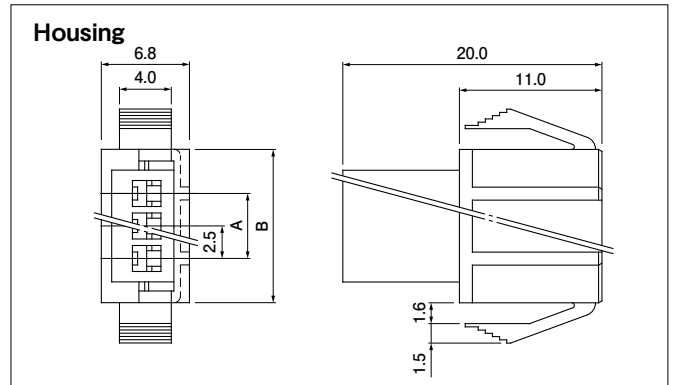

No. of circuits	Model No.	Dimensions (mm)		Q'ty/bag
		A	B	
2	HMR-02V	2.5	9.3	1,000
3	HMR-03V	5.0	11.8	500
4	HMR-04V	7.5	14.3	500
8	HMR-08V	17.5	24.3	500
12	HMR-12V	27.5	34.3	500

### Material and Finish

PA 66, UL94V-0

RoHS2 compliance

## Receptacle / Crimp style HR connector

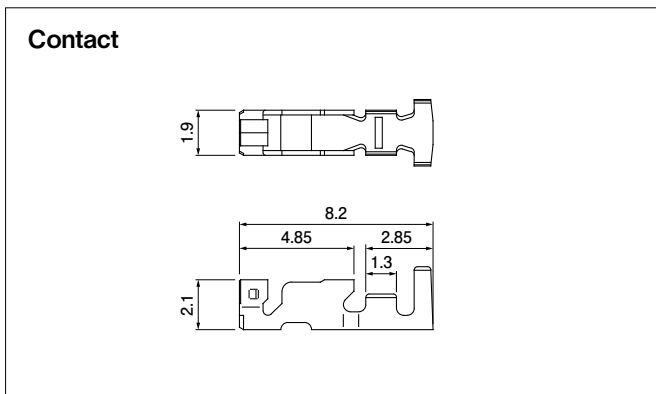

Model No.	Applicable wire		Insulation O.D. (mm)	Q'ty/reel
	mm <sup>2</sup>	AWG #		
SHR-001T-P0.6	0.13~0.33	26~22	1.3~1.7	9,000

### Material and Finish

Phosphor bronze, tin-plated (reflow treatment)

RoHS2 compliance

Contact	Crimping machine	Applicator		
		Crimp applicator	Dies	Crimp applicator with dies
SHR-001T-P0.6	AP-K2N	MKS-L	MK/SHR/MR-001-06	APLMK SHR/MR001-06

Note: Contact JST for fully automatic crimping applicator.

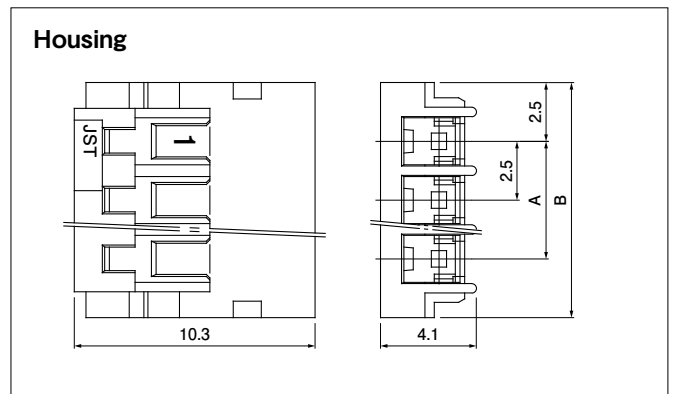

No. of circuits	Model No.	Dimensions (mm)		Q'ty/bag
		A	B	
2	HRP-02-S	2.5	7.5	2,000
3	HRP-03-S	5.0	10.0	2,000
4	HRP-04-S	7.5	12.5	1,000
8	HRP-08-S	17.5	22.5	500
12	HRP-12-S	27.5	32.5	500

### Material and Finish

PA 66, UL94V-0

RoHS2 compliance

# HM CONNECTOR

## Receptacle / Insulation displacement HR connector

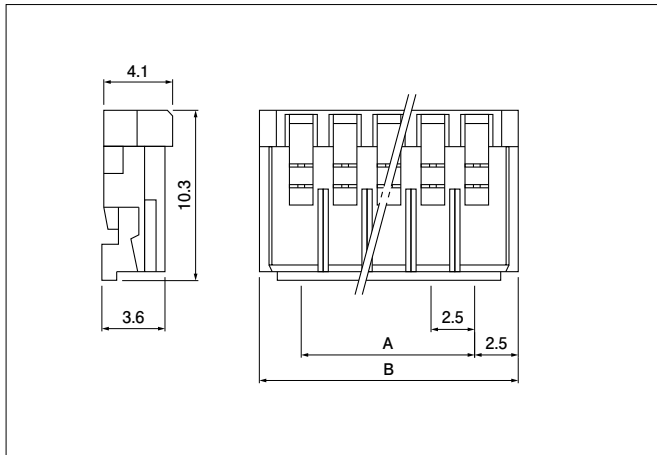

No. of circuits	Model No.			Dimensions (mm)		Q'ty/ bag
	# 28	# 26	# 24	A	B	
2	02HR-8M-P-N	02HR-6S-P-N	02HR-4K-P-N	2.5	7.5	1,000
3	03HR-8M-P-N	03HR-6S-P-N	03HR-4K-P-N	5.0	10.0	1,000
4	04HR-8M-P-N	04HR-6S-P-N	04HR-4K-P-N	7.5	12.5	1,000
8	08HR-8M-P-N	08HR-6S-P-N	08HR-4K-P-N	17.5	22.5	500
12	12HR-8M-P-N	12HR-6S-P-N	12HR-4K-P-N	27.5	32.5	500

### Material and Finish

Contact: Phosphor bronze, tin-plated (reflow treatment)  
Housing: PA 66, UL94V-0

RoHS2 compliance