

Solderless terminals

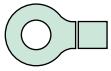

**RING TONGUE (R type) Non-insulated, bent at 90°**

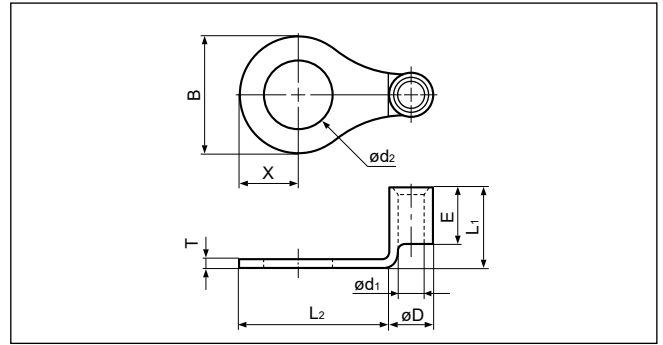
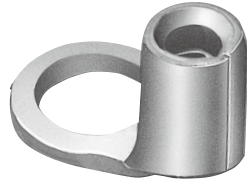
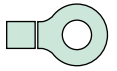

Certificate No.: E42024 LR20812

Applicable Wire AWG#(mm <sup>2</sup> )	Stud size		Part No.	Standard	Dimensions mm (in.)									Tool No.				Qty/ box
	American	Metric			ød <sub>2</sub>	B	L <sub>1</sub>	L <sub>2</sub>	X	E	øD	ød <sub>1</sub>	T	YHT-2210 YHT-2214M	YA-1	YA-2	YA-4	
22 to 16 (0.25 to 1.65)	1-2	2	L1.25-2		2.2 (.087)	5.5 (.217)	6.5 (.256)	5.8 (.228)	2.8 (.110)	4.8 (.189)	3.4 (.134)	1.7 (.067)	0.8 (.031)	o	o	o	1,000	
	3-4	3	L1.25-3		3.2 (.126)	5.5 (.217)	6.5 (.256)	5.8 (.228)	2.8 (.110)									
	3-4	3	L1.25-M3.3		3.2 (.126)	6.6 (.260)	6.5 (.256)	8.5 (.335)	3.3 (.130)									
	5-6	3.5	L1.25-3.7		3.7 (.146)	5.5 (.217)	6.5 (.256)	5.8 (.228)	2.8 (.110)									
	5-6	3.5	L1.25-M3		3.7 (.146)	6.6 (.260)	6.5 (.256)	8.5 (.335)	3.3 (.130)									
	8	4	L1.25-M4		4.3 (.169)	6.6 (.260)	6.5 (.256)	8.5 (.335)	3.3 (.130)									
	8	4	L1.25-4		4.3 (.169)	8.0 (.315)	6.5 (.256)	10.0 (.394)	4.0 (.157)									
	10	5	L1.25-5		5.3 (.209)	8.0 (.315)	6.5 (.256)	10.0 (.394)	4.0 (.157)									
16 to 14 (1.04 to 2.63)	1/4	6	L1.25-6		6.4 (.252)	11.6 (.457)	6.5 (.256)	16.0 (.630)	5.8 (.228)	4.8 (.189)	4.1 (.161)	2.3 (.091)	0.8 (.031)	o	o	o	1,000	
	3-4	3	L2-3		3.2 (.126)	8.5 (.335)	6.5 (.256)	11.0 (.433)	4.3 (.169)									
	5-6	3.5	L2-M3		3.7 (.146)	6.6 (.260)	6.5 (.256)	8.5 (.335)	3.3 (.130)									
	5-6	3.5	L2-P3.5		3.7 (.146)	7.0 (.276)	6.5 (.256)	10.2 (.402)	3.5 (.138)									
	8	4	L2-M4		4.3 (.169)	6.6 (.260)	6.5 (.256)	8.5 (.335)	3.3 (.130)									
	8	4	L2-P4		4.3 (.169)	7.0 (.276)	6.5 (.256)	10.2 (.402)	3.5 (.138)									
	8	4	L2-4		4.3 (.169)	8.5 (.335)	6.5 (.256)	11.0 (.433)	4.3 (.169)									
	10	5	L2-5		5.3 (.209)	9.5 (.374)	6.5 (.256)	11.0 (.433)	4.8 (.189)									
12 to 10 (2.63 to 6.64)	5/16	8	L2-8		8.4 (.331)	12.0 (.472)	6.5 (.256)	16.0 (.630)	6.0 (.236)	6.8 (.268)	5.6 (.220)	3.4 (.134)	1.0 (.039)	o	o	o	500	
	3-4	3	L5.5-3		3.2 (.126)	9.5 (.374)	9.5 (.374)	11.0 (.433)	4.8 (.189)									
	8	4	L5.5-4		4.3 (.169)	9.5 (.374)	9.5 (.374)	11.0 (.433)	4.8 (.189)									
	10	5	L5.5-5		5.3 (.209)	9.5 (.374)	9.5 (.374)	11.0 (.433)	4.8 (.189)									
	1/4	6	L5.5-6		6.4 (.252)	12.0 (.472)	9.8 (.386)	16.8 (.661)	6.0 (.236)									
	5/16	8	L5.5-8		8.4 (.331)	15.0 (.591)	9.5 (.374)	19.0 (.748)	7.5 (.295)									
	3/8	10	L5.5-10		10.5 (.413)	15.0 (.591)	9.5 (.374)	19.0 (.748)	7.5 (.295)									
	1/2	14	L5.5-14		15.0 (.591)	32.0(1.260)	9.5 (.374)	39.5(1.555)	16.0 (.630)									
	5/8	16	L5.5-16		17.0 (.669)	32.0(1.260)	9.5 (.374)	39.5(1.555)	16.0 (.630)									
	11/16	18	L5.5-18		19.0 (.748)	32.0(1.260)	9.5 (.374)	39.5(1.555)	16.0 (.630)									
3/4	20	L5.5-20	21.0 (.827)	32.0(1.260)	9.5 (.374)	39.5(1.555)	16.0 (.630)											

Note:1) The part numbers indicated in the above table are for products with a brazed seam.  
 When ordering products with a butted seam, add the prefix "WS" to the part number (ex. L1.25-M3 -> **WSL1.25-M3**).  
 2) Delivery lead times may vary depending on the product. Contact JST for details.

Solderless terminals

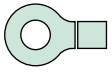

**RING TONGUE (R type)** Non-insulated, bent at 90°

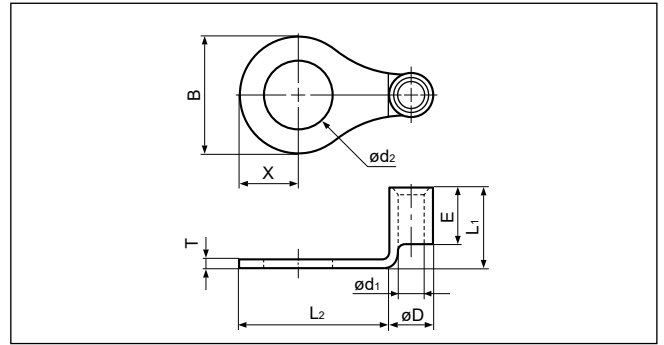
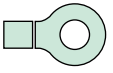

Applicable Wire AWG#(mm <sup>2</sup> )	Stud size		Part No.	Standard	Dimensions mm (in.)									Tool No.		Qty/box
	American	Metric			ød <sub>2</sub>	B	L <sub>1</sub>	L <sub>2</sub>	X	E	øD	ød <sub>1</sub>	T	YA-5	YPT-60N	
8 (6.64 to 10.52)	8	4	L8-4	UL SP	4.3 (.169)	12.0 (.472)	10.8 (.425)	14.0 (.551)	6.0 (.236)	8.5 (.335)	7.1 (.280)	4.5 (.177)	1.2 (.047)	o	o	500
	10	5	L8-5		5.3 (.209)	12.0 (.472)	10.8 (.425)	14.0 (.551)	6.0 (.236)							
	1/4	6	L8-6		6.4 (.252)	12.0 (.472)	10.8 (.425)	14.0 (.551)	6.0 (.236)							
	1/4	6	L8-L6		6.4 (.252)	15.0 (.591)	12.0 (.472)	19.0 (.748)	7.5 (.295)							
	5/16	8	L8-8		8.4 (.331)	15.0 (.591)	12.0 (.472)	19.0 (.748)	7.5 (.295)							
	1/2	14	L8-14		15.0 (.591)	31.6(1.244)	12.0 (.472)	39.0(1.535)	15.8 (.622)							
	5/8	16	L8-16		17.0 (.669)	31.6(1.244)	12.0 (.472)	39.0(1.535)	15.8 (.622)							
	11/16	18	L8-18		19.0 (.748)	31.6(1.244)	12.0 (.472)	39.0(1.535)	15.8 (.622)							
3/4	20	L8-20	21.0 (.827)	31.6(1.244)	12.0 (.472)	39.0(1.535)	15.8 (.622)	200								
10	5	L14-5	5.3 (.209)	12.0 (.472)	14.5 (.571)	16.5 (.650)	6.0 (.236)		10.5 (.413)	9.0 (.354)	5.8 (.228)	1.5 (.059)	o	o	200	
6 (10.52 to 16.78)	1/4	6	L14-6	6.4 (.252)	12.0 (.472)	14.5 (.571)	16.5 (.650)	6.0 (.236)								
	5/16	8	L14-8	8.4 (.331)	16.0 (.630)	14.5 (.571)	19.8 (.780)	8.0 (.315)								
	3/8	10	L14-10	10.5 (.413)	16.0 (.630)	14.5 (.571)	19.8 (.780)	8.0 (.315)								
	1/2	12	L14-12	13.0 (.512)	22.0 (.866)	14.5 (.571)	27.5(1.083)	11.0 (.433)								100
10	5	L22-5	5.3 (.209)	16.5 (.650)	16.8 (.661)	18.5 (.728)	8.3 (.327)	12.0 (.472)	11.5 (.453)	7.7 (.303)	1.8 (.071)	o	o	100		
4 (16.78 to 26.66)	1/4	6	L22-6	6.4 (.252)	16.5 (.650)	16.8 (.661)	18.5 (.728)								8.3 (.327)	
	5/16	8	L22-8	8.4 (.331)	16.5 (.650)	16.8 (.661)	18.5 (.728)								8.3 (.327)	
	3/8	10	L22-10	10.5 (.413)	17.5 (.689)	17.0 (.669)	21.5 (.847)								8.8 (.346)	
	7/16	11	L22-11	11.5 (.453)	22.0 (.866)	16.5 (.650)	27.5(1.083)								11.0 (.433)	
	1/2	12	L22-12	13.0 (.512)	22.0 (.866)	16.5 (.650)	27.5(1.083)								11.0 (.433)	

Note:1) Delivery lead times may vary depending on the product. Contact JST for details.